

SOT161A

CDFM8; blister pack; standard product orientation 12NC
ending 112

Rev. 2 — 1 September 2015

AMPLEON
Packing information

1. Packing method

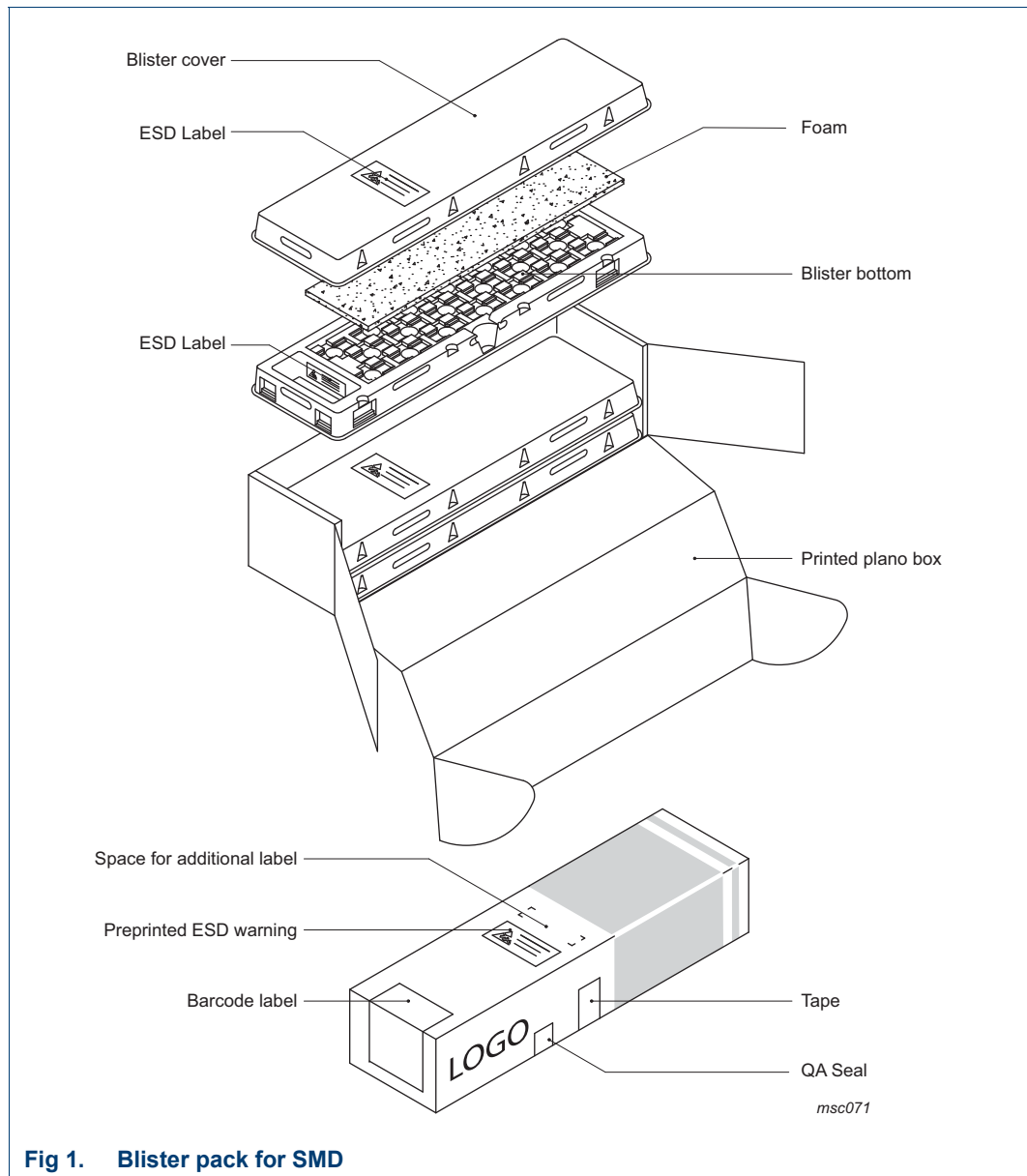

Table 1. Packing information

Package version	12NC ending	SPQ per carrier	PQ (pcs)	Carriers per box	Outer box dimensions l x w x h (mm)
SOT161A	112	20	60	3	315 x 118 x 78

2. Revision history

Table 2. Revision history

Document ID	Release date	Packing document status	Change notice	Supersedes
SOT161A_112#2	20150901	Packing information	-	SOT161A_112
Modifications:	<ul style="list-style-type: none">• The format of this document has been redesigned to comply with the new identity guidelines of Ampleon.• Legal texts have been adapted to the new company name where appropriate.			
SOT161A_112	20121018	Packing information	-	-

Limited warranty and liability

Information in this document is believed to be accurate and reliable. However, Ampleon does not give any representations or warranties, expressed or implied, as to the accuracy or completeness of such information and shall have no liability for the consequences of use of such information.

© Ampleon The Netherlands B.V. 2015.

All rights reserved.

For more information, please visit: <http://www.ampleon.com>

For sales office addresses, please visit: <http://www.ampleon.com/sales>

Date of release: 1 September 2015

Document identifier: SOT161A_112#2