

Document information

Info	Content
Keywords	BLF578, high-voltage LDMOS, 1 kW, broadcast, ISM
Abstract	Full 1 kW CW output power and an efficiency of 70 % can be reached with a BLF578 VHF power LDMOS transistor at 352 MHz. The gain compression is about 1.5 dB at this output level.

Revision history

Rev	Date	Description
AN10967#3	20150901	Modifications <ul style="list-style-type: none">• The format of this document has been redesigned to comply with the new identity guidelines of Ampleon.• Legal texts have been adapted to the new company name where appropriate.
AN10967#2	20121120	Application note
AN10967#1	20110323	Initial version

Contact information

For more information, please visit: <http://www.ampleon.com>

For sales office addresses, please visit: <http://www.ampleon.com/sales>

1. Introduction

This application note describes the results of a BLF578 demo board at 352 MHz producing 1 kW CW with an efficiency of approximately 70 %.

This amplifier design can be used in synchrotron particle accelerators, but can also be used for other applications at this frequency.

The demo board is built on a full copper baseplate including a water cooling channel. The transistor is bolted onto the copper baseplate using heat conductive compound.

The demo board has been tested at $V_{DS} = 50\text{ V}$ and 48 V , $I_{Dq} = 200\text{ mA}$ for the total device. Gain and efficiency were measured CW at 352 MHz. Quiescent drain current (I_{Dq}) is adjusted by connecting a voltage supply to the respective connections on the input circuit. The procedure to adjust the I_{Dq} is to start with a low voltage of approximately 0.5 V and increase the voltage slowly until the I_{Dq} reaches 200 mA. The gate bias voltage (V_{GG}) value needed is approximately 1.5 V.

Results of the measurements are shown in [Section 2](#).

A picture of the amplifier is shown in [Figure 1](#). The size of the demo board is 80 mm × 192 mm including the connectors.

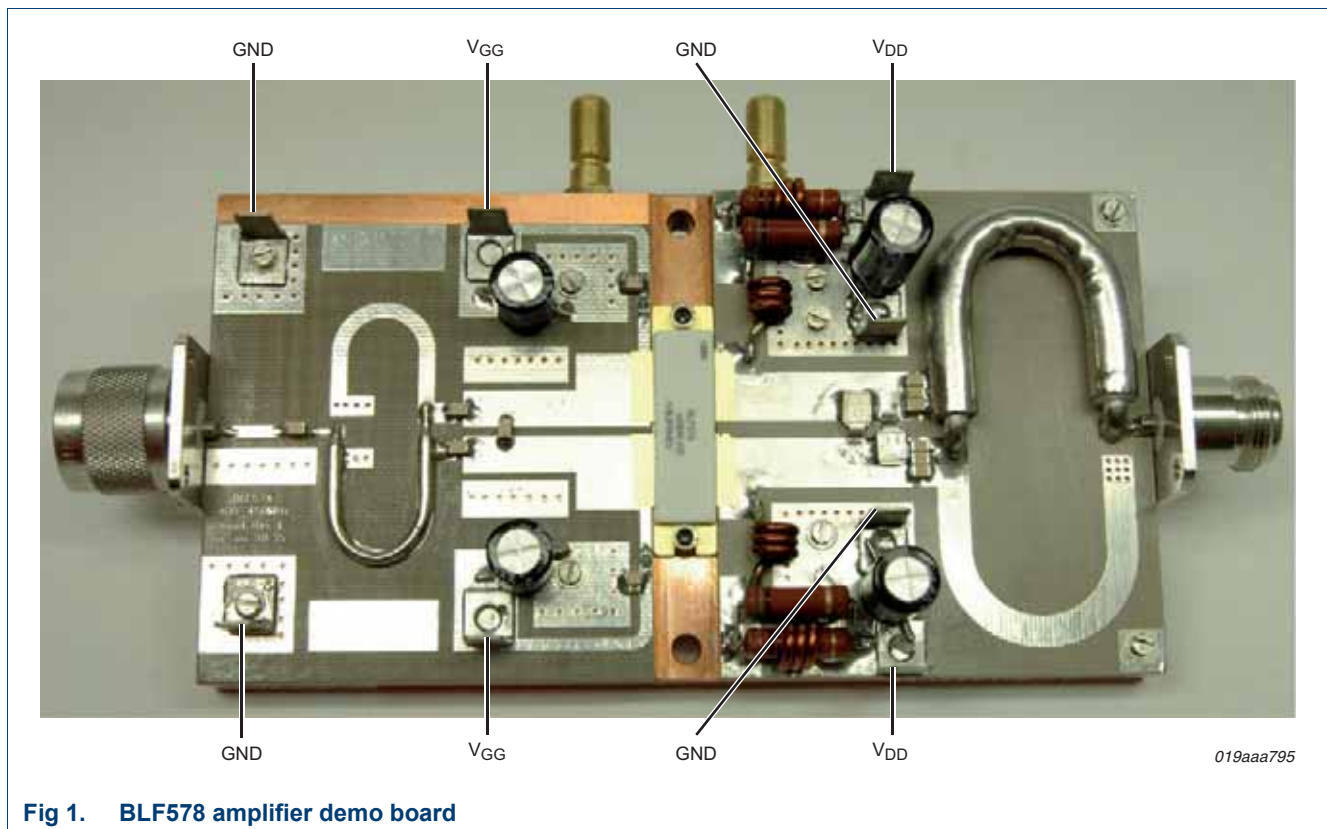
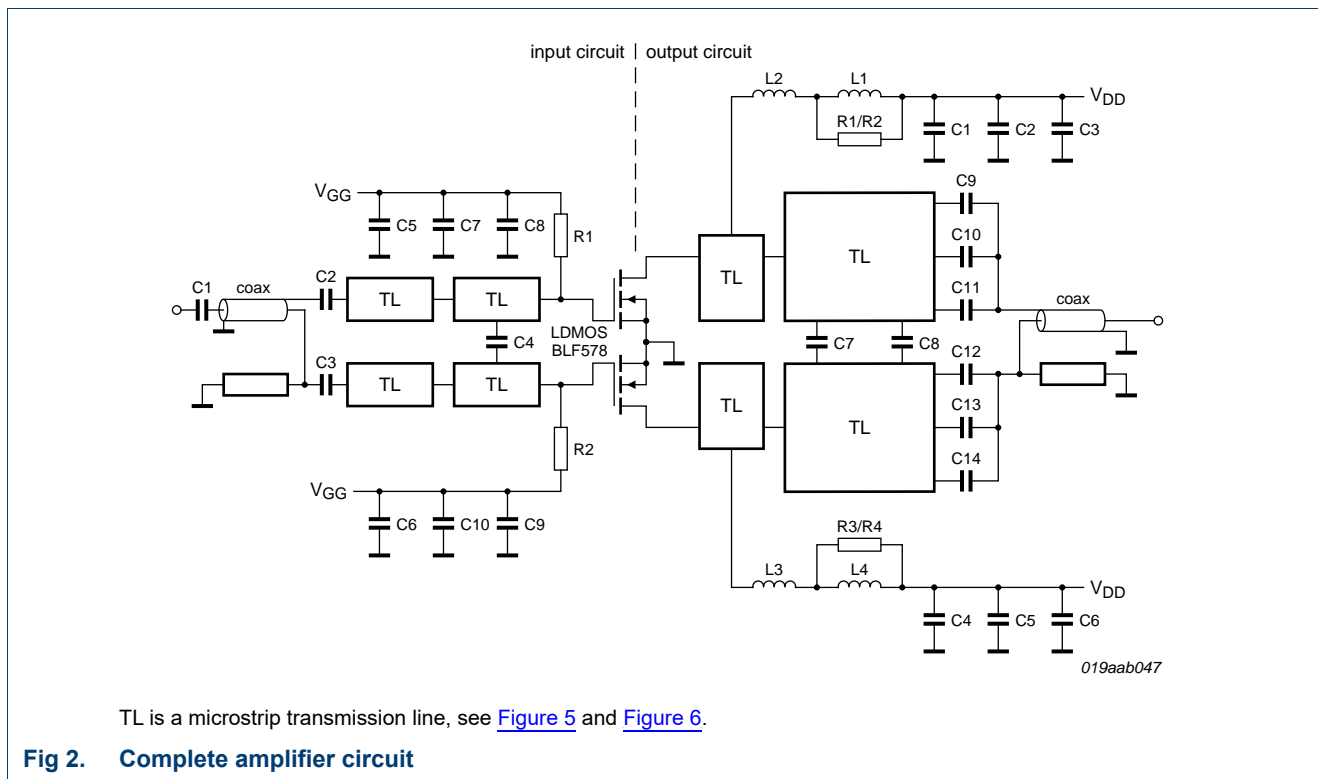

Fig 1. BLF578 amplifier demo board

2. Test circuit

2.1 Schematic diagram



The demo board was built on Printed-Circuit Board (PCB) material Taconic RF35, height = 0.79 mm, $\epsilon_r = 3.5$.

The input circuit uses PCB material with 0.035 mm copper thickness and the output circuit uses 0.070 mm copper thickness due to the high currents.

Cooling is provided by connecting a water supply to the baseplate cooling tubes.

The two matching capacitors, C7 and C8 located just before the output balun are Cornell Dubilier, high quality, SMT capacitors type MIN02-002, suited for high-power use.

The circuit can be slightly tuned for different combinations of 1 dB power and efficiency by varying the value and position of C7 and C8 in the output circuit. Shifting C7 a little towards the transistor or decreasing its value results in a higher 1 dB power and a lower efficiency.

Likewise, slightly increasing C7/C8 decreases the 1 dB power and slightly increase efficiency

2.2 Measurement data

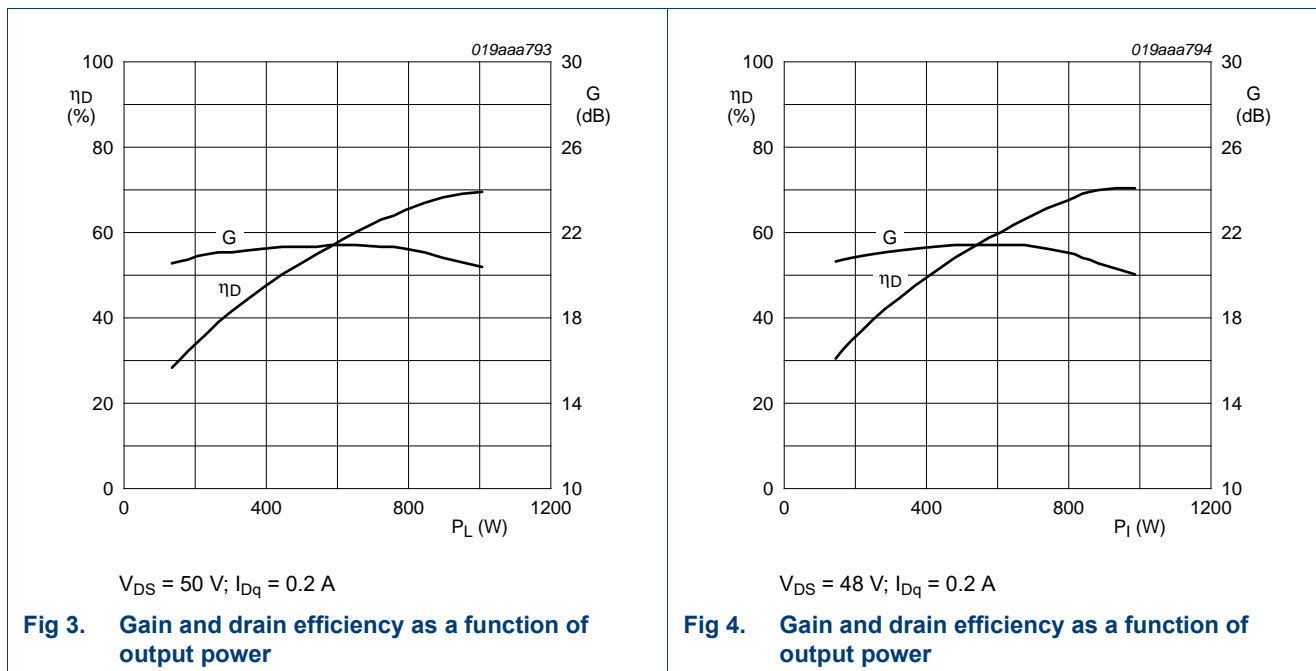

2.3 Thermal behavior of the output circuit

A list of measured temperatures in the output circuit is shown in [Table 1](#). The balun shows highest temperatures around 75 °C.

The matching capacitor C7 (closest to the transistor) in the output circuit shows the highest temperature of 155 °C. The CDE MIN02 capacitors are rated at a maximum operating temperature of 200 °C.

The junction temperature of the LDMOS die was not measured but estimated between 150 °C to 160 °C. The estimation was based on a cooling water temperature of 50 °C and a thermal resistance from junction to heatsink $R_{th(j-h)}$ of 0.25 K/W. It also assumed a power dissipation of approximately 400 W (operating at $P_{load} = 1$ kW and $\eta_D = 70$ %).

Table 1. Output circuit

Component	Temperature (°C)
Stripline between D and Balun	140
C7	155
C8	140
Capacitors to balun C9 to C14	130
Balun semirigid coax hottest spot	75
Balun lower track hottest spot	85
Ear of flange LDMOS	37

2.4 Layout and components

2.4.1 Output circuit

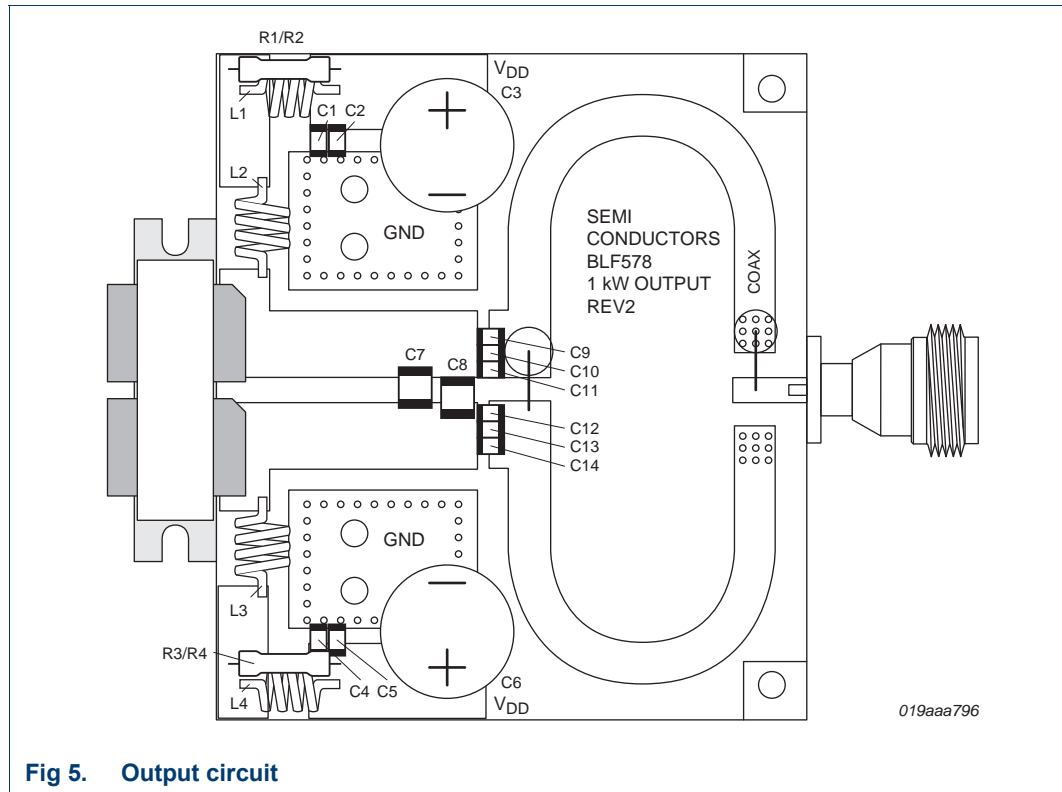

Fig 5. Output circuit

Table 2. Output circuit components

Component	Value	Type / manufacturer
PCB	Taconic RF35, 0.07 mm, Cu	Taconic
R1	15 Ω (connected parallel to R2 and L1)	3 W
R2, R4	10 Ω	3 W
R3	15 Ω (connected parallel to R4 and L4)	3 W
L1, L2, L3, L4	3 turns, 1.7 mm wire, 4 mm diameter, close wound	enamel copper wire
C1, C4	100 pF	ATC100B
C2, C5	1 nF	ATC100B
C3, C6	220 μF, 63 V	electrolytic
C7, C8	22 pF (C7, 20.5 mm from transistor case edge)	Cornell Dubilier MIN02
C9, C10, C11	47 pF	ATC100B
C12, C13, C14		
Coax	Z _o = 25 Ω	UT300C-25 micro-coax
N connector	female, 50 Ω	Suhner
LDMOS	BLF578	Ampleon

2.4.2 Input circuit

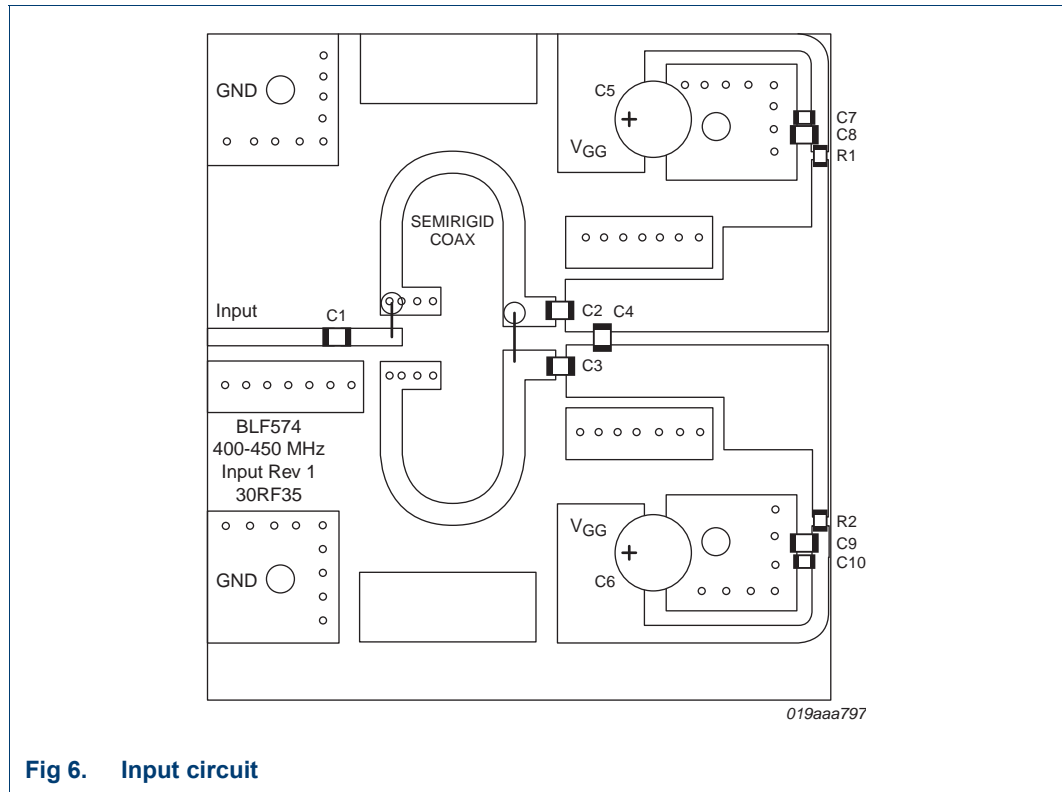

Fig 6. Input circuit

Table 3. Input circuit components

Designator	Description	Manufacturer
PCB	Taconic RF35, 0.035 mm, Cu	Taconic
R1, R2	47 Ω	SMD 1206
C1	100 pF	ATC100B
C2, C3	56 pF	ATC100B
C4	22 pF (22 mm from transistor case)	ATC100B
C5, C6	100 μ F 63 V	electrolytic
C7, C10	100 nF	Murata X7R
C8, C9	100 pF	ATC100B
Coax	$Z_o = 25 \Omega$	UT90C-25 micro-coax
N connector	male, 50 Ω	Suhner

3. Abbreviations

Table 4. Abbreviations

Acronym	Description
CW	Continuous Wave
ISM	Industrial, Scientific and Medical
LDMOS	Laterally Diffused Metal-Oxide Semiconductor
PCB	Printed-Circuit Board

4. Glossary

I_{Dq} — quiescent drain current

V_{DD} — drain supply voltage

V_{GG} — gate bias voltage

5. Legal information

5.1 Definitions

Draft — The document is a draft version only. The content is still under internal review and subject to formal approval, which may result in modifications or additions. Ampleon does not give any representations or warranties as to the accuracy or completeness of information included herein and shall have no liability for the consequences of use of such information.

5.2 Disclaimers

Limited warranty and liability — Information in this document is believed to be accurate and reliable. However, Ampleon does not give any representations or warranties, expressed or implied, as to the accuracy or completeness of such information and shall have no liability for the consequences of use of such information. Ampleon takes no responsibility for the content in this document if provided by an information source outside of Ampleon.

In no event shall Ampleon be liable for any indirect, incidental, punitive, special or consequential damages (including - without limitation - lost profits, lost savings, business interruption, costs related to the removal or replacement of any products or rework charges) whether or not such damages are based on tort (including negligence), warranty, breach of contract or any other legal theory.

Notwithstanding any damages that customer might incur for any reason whatsoever, Ampleon's aggregate and cumulative liability towards customer for the products described herein shall be limited in accordance with the *Terms and conditions of commercial sale* of Ampleon.

Right to make changes — Ampleon reserves the right to make changes to information published in this document, including without limitation specifications and product descriptions, at any time and without notice. This document supersedes and replaces all information supplied prior to the publication hereof.

Suitability for use — Ampleon products are not designed, authorized or warranted to be suitable for use in life support, life-critical or safety-critical systems or equipment, nor in applications where failure or malfunction of an Ampleon product can reasonably be expected to result in personal injury, death or severe property or environmental damage. Ampleon and its suppliers accept no liability for inclusion and/or use of Ampleon products in such equipment or applications and therefore such inclusion and/or use is at the customer's own risk.

Applications — Applications that are described herein for any of these products are for illustrative purposes only. Ampleon makes no representation or warranty that such applications will be suitable for the specified use without further testing or modification.

Customers are responsible for the design and operation of their applications and products using Ampleon products, and Ampleon accepts no liability for any assistance with applications or customer product design. It is customer's sole responsibility to determine whether the Ampleon product is suitable and fit for the customer's applications and products planned, as well as for the planned application and use of customer's third party customer(s). Customers should provide appropriate design and operating safeguards to minimize the risks associated with their applications and products.

Ampleon does not accept any liability related to any default, damage, costs or problem which is based on any weakness or default in the customer's applications or products, or the application or use by customer's third party customer(s). Customer is responsible for doing all necessary testing for the customer's applications and products using Ampleon products in order to avoid a default of the applications and the products or of the application or use by customer's third party customer(s). Ampleon does not accept any liability in this respect.

Export control — This document as well as the item(s) described herein may be subject to export control regulations. Export might require a prior authorization from competent authorities.

5.3 Trademarks

Notice: All referenced brands, product names, service names and trademarks are the property of their respective owners.

Any reference or use of any 'NXP' trademark in this document or in or on the surface of Ampleon products does not result in any claim, liability or entitlement vis-à-vis the owner of this trademark. Ampleon is no longer part of the NXP group of companies and any reference to or use of the 'NXP' trademarks will be replaced by reference to or use of Ampleon's own Any reference or use of any 'NXP' trademark in this document or in or on the surface of Ampleon products does not result in any claim, liability or entitlement vis-à-vis the owner of this trademark. Ampleon is no longer part of the NXP group of companies and any reference to or use of the 'NXP' trademarks will be replaced by reference to or use of Ampleon's own trademarks.

6. Contents

1	Introduction	3
2	Test circuit	4
2.1	Schematic diagram	4
2.2	Measurement data	5
2.3	Thermal behavior of the output circuit	5
2.4	Layout and components	6
2.4.1	Output circuit	6
2.4.2	Input circuit	7
3	Abbreviations	8
4	Glossary	8
5	Legal information	9
5.1	Definitions	9
5.2	Disclaimers	9
5.3	Trademarks	9
6	Contents	10

Please be aware that important notices concerning this document and the product(s) described herein, have been included in section 'Legal information'.

© Ampleon The Netherlands B.V. 2015. All rights reserved.

For more information, please visit: <http://www.ampleon.com>

For sales office addresses, please visit: <http://www.ampleon.com/sales>

Date of release: 1 September 2015

Document identifier: AN10967#3