

Package outline drawing:	units in mm.	Tolerances unless otherwise stated:	Revision: 0
OMP-780-16F-1		Dimension: ± 0.05	Revision date: 3/1/2018
		Angle: $\pm 1^\circ$	
		 Third angle projection	Sheet 1 of 2

Drawing Notes

Items	Description
(1)	Dimensions are excluding mold protrusion. Areas located adjacent to the leads have a maximum mold protrusion of 0.25 mm (per side) and 0.62 mm max. in length. In between the 14 leads the protrusion is 0.25 mm. max. At all other areas the mold protrusion is maximum 0.15 mm per side. See also detail B.
(2)	The metal protrusion (tie bars) in the corner will not stick out of the molding compound protrusions (detail A).
(3)	The lead dambar (metal) protrusions are not included. Add 0.14 mm max to the total lead dimension at the dambar location.
(4)	The lead coplanarity over all leads is 0.1 mm maximum.
(5)	Dimension is measured 0.5 mm from the edge of the top package body.
(6)	The hatched area indicates the exposed metal heatsink.
(7)	The leads and exposed heatsink are plated with matte Tin (Sn).

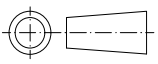
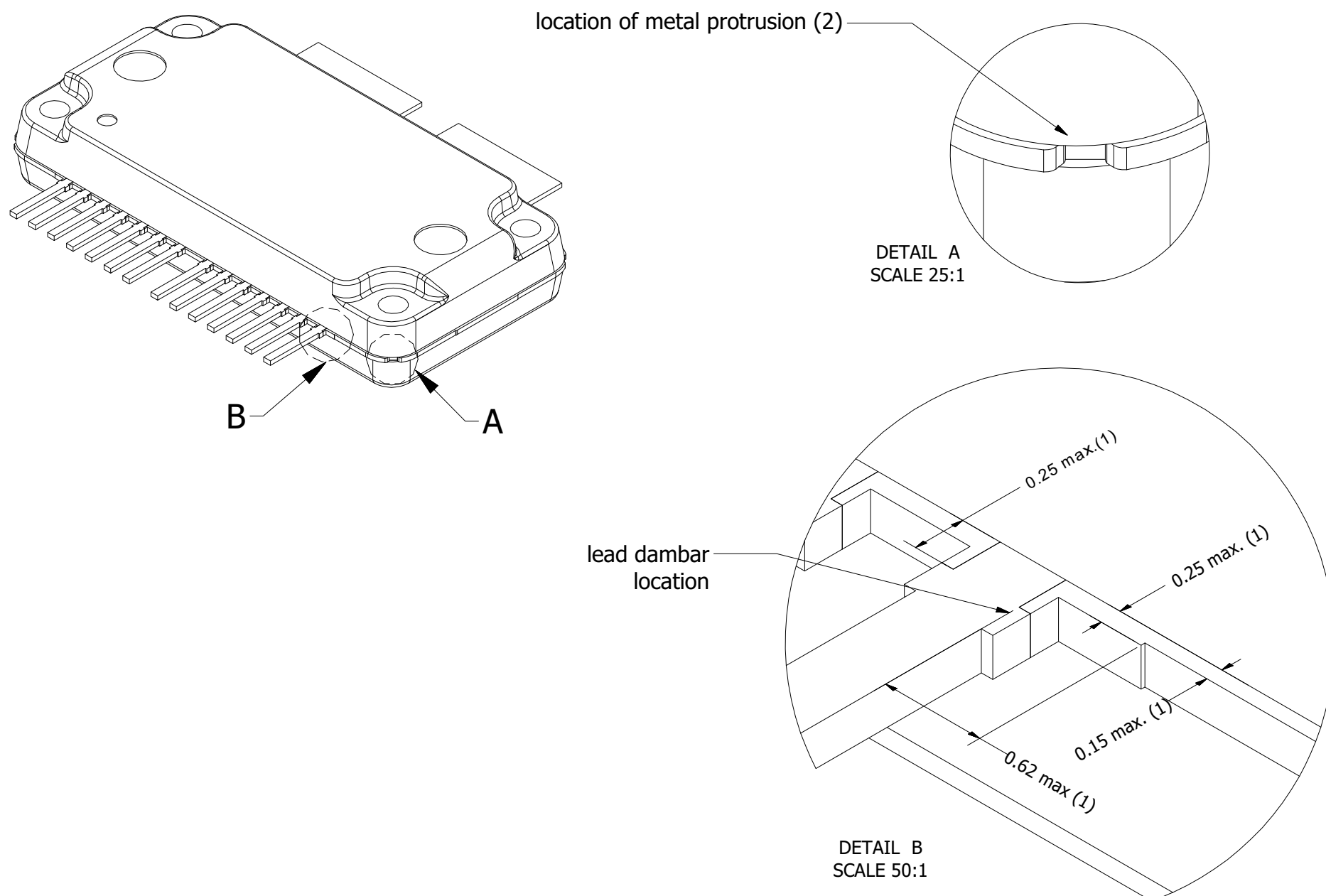

Package outline drawing:

OMP-780-16F-1

units in mm.

Tolerances unless otherwise stated:

Dimension: ± 0.05

Angle: $\pm 1^\circ$

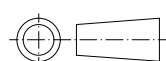

Third angle projection

Revision:

0

Revision date:

3/1/2018

Sheet 2 of 2