

Ampleon's Ultra Wideband Doherty (UWD) for TV Transmitters White Paper

Bill Goumas, Principal Application Engineer, Peter Forth, Multimarket Application Manager

Abstract

Ampleon is the #1 supplier of RF Power transistors for FM/VHF/TV broadcast transmitters. The key features of the latest generation technology of LDMOS transistors are unprecedented ruggedness along with best-in class gain and efficiency. Ampleon is recognized as expert in Doherty circuit and device technology and their application to the UHF-TV market. Trends in the UHF-TV market are discussed here as background information.

A proof of concept LDMOS based ultra-wideband broadcast Doherty (UWD) amplifier is also presented here. This amplifier is a starting point in Ampleon's family of high power UWDs. This high-power Doherty design technique enables fractional bandwidths > 50 %. This amplifier covers 470 - 803 MHz with Peak power of > 750 W, DVB-T power of > 115 W and efficiencies of 38 - 47 %. Pre-distortability is demonstrated by satisfying the digital TV linearity requirement of -38 dBc with a commercial DVB-T exciter.

Roadmaps for Ampleon's UWD amplifiers along with a summary of our existing Demo Boards are shown. The significant impact of the UWD on transmitter operating cost is presented.

1. Ampleon: Introduction and Background

Created in 2015, Ampleon is shaped by 50 years of RF power leadership. Recently being spun-off from NXP Semiconductors, the company is set to exploit the full potential of data and energy transfer in RF. Ampleon today has more than 1,250 employees worldwide, dedicated to creating optimal value for customers. Its innovative, yet consistent portfolio offers products and solutions for a wide range of applications, such as cellular base stations, radio / TV/broadcasting, radar, air traffic control, cooking, lighting, industrial lasers and medical. For details on the leading global partner in RF Power, visit: www.ampleon.com

2. UHF TV Market and Trends

Chapter 2,3,4 and 5 and parts of Chapter 8 are taken from [1]. Some of the detailed technical aspects have been left out of this article. See [1] for the complete detailed report. UHF broadcast transmitters that transmit digital TV signals [11] (e.g. DVB - T2) are typically accomplished through the use of wideband push-pull class-AB power amplifiers [2]. As such,

the achieved average efficiency is limited and falls in the 25 % - 30 % range [2], [3]. Due to the very high output power levels involved in these systems (typically $P_{avg} = 0.5 \text{ kW} - 30 \text{ kW}$), maximizing the broadcast efficiency is extremely important in reducing the electricity bill and hence the overall operating cost. At this moment, the broadcast industry is actively looking for a high-efficiency alternative to their current RF power amplifier blocks. Although various high-efficiency architectures exist [2], [3], e.g. envelope tracking (ET) and envelope elimination and restoration (ERR) [2], which can provide wide RF bandwidth along with high efficiency. However, their application to broadcast transmitters is complicated and costly, mainly due the very high output powers involved. In contrast, Doherty amplification [2] is a cost effective technique that is widely used in cellular base station transmitters. However, high power Doherty amplifiers are notorious for their narrow RF bandwidth [4] (typically 5 % to 10 % fractional bandwidth). The solution to this problem is a wideband (> 30 % fractional bandwidth) Doherty amplifier.

Although, recently there have been a number of wideband Doherty amplifier techniques presented in literature [3][4][6]

[5], most of these techniques are inherently low power and require complex input signal conditioning, like dual input drive and drain voltage control [5]. Chapters 3, 4 and 5 address the needs of broadcast transmitters by presenting a simple but effective design technique. This technique will allow Ampleon to develop very wideband Doherty amplifiers (up to 60 % fractional bandwidth) which are suited for high power levels. The ideas presented here are verified by a 115 W (750 W peak power) Doherty amplifier which covers the entire broadcast frequency band with average efficiencies of 38 % to 47 % while maintaining a minimum output PAR of 8 dB. These results were obtained by using standard 50 V LDMOS technology (BLF888D) without any added costs or increased complexity. This amplifier circuit can be used as a building block for achieving power levels up to the multi kW level by combining multiple similar amplifier stages.

The original article with the technical details on the design, using the BLF888D, was published at MTT-S in 2014. Since 2014, Ampleon has made considerable progress in increasing the power level for an UWB Doherty. Our current flagship device is the BLD888E and we have reference designs using this device that cover the 470 - 806 MHz range in 3 sub-band. Details on these 3 reference designs are in Fig. 8 in Chapter 6. Power level is 150 W DVB-T.

The focus at Ampleon has been on the 470 - 608 MHz range for our development of the 150 W average DVB-T stage. As is shown in Fig. 8 in Chapter 6, we have other reference designs / demo boards to address the complete 470 - 870 MHz range. The focus on 470 - 608 has been driven by the migration of the upper end of the UHF TV band in the US for other purposes. If you are in a country / area which needs the full range or a different range, please contact Ampleon and we will present our best solution.

3. Wideband Doherty Amplifier Background

The factors affecting the bandwidth of the Doherty Power Amplifier (DPA) are quite well-known and documented in detail in [3] and [4]. It was shown in [4] that by:

- compensating the output capacitance of the PA devices in a wideband fashion and
- interchanging the position of power combiner and impedance transformation

it is possible to significantly increase the bandwidth of the DPA. However the achievable DPA bandwidth is still limited by the bandwidth of the impedance inverter, which for a $\lambda/4$ transmission line (QWTL) based impedance inverter is equal to 28 % (using a 10 % relative efficiency drop condition at the band edges) [3][4]. Therefore, in order to address the bandwidth requirements of broadcast industry, in this work, the techniques presented in [4] are extended with a wideband

impedance inverter to reach a fractional RF bandwidth greater than 50 %.

A very wideband impedance inverter can be created by adding an open circuited half-wave line ($\lambda/2$) to the load end of the QWTL as shown in Fig. 1a.

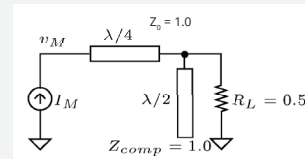

Fig. 1a. Wideband Impedance Inverter

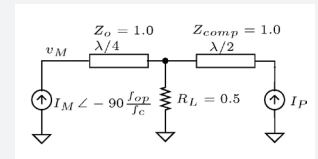

Fig. 1b. Wideband Doherty Power Amplifier

The resulting loading conditions for this DPA are shown in the Fig. 2 along with the results obtained from a DPA based on a conventional QWTL impedance inverter. Fig. 2 shows that the addition of the $\lambda/2$ line results in a much wider load modulation bandwidth (solid line vs dotted line). This circuit structure also helps to flatten the efficiency bandwidth in practical designs. The related achievable efficiency bandwidth is estimated to be more than 60 %. This is compared to the ~ 25 % fractional bandwidth estimated for a simple QWTL inverter. The peaking device can be connected to the open end of the $\lambda/2$ compensation line without any loss of functionality at the back-off power level as shown in Fig. 1b.

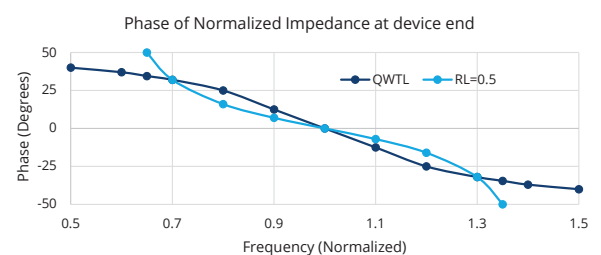
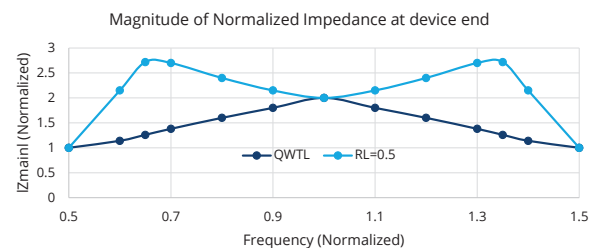

Fig. 2. Magnitude and phase of normalized impedance seen at device end of the wideband impedance inverter

The impedance of the compensation line must be chosen to be equal to the optimum loading impedance of the peaking device. If the proper input phase relations are enforced as discussed in Section 4.B, there will be no bandwidth

restriction on the proposed wideband Doherty under full-power level conditions (assuming the use of ideal PA devices). The details of this design and bandwidth estimate can be found in [1]. After this initial estimate, we are ready to proceed on a detailed design and will use the Ampleon BLF888D.

4. Circuit Design

A. Wideband Output Power Combiner Design

So far, in the analysis of the wideband Doherty amplifier, we have considered ideal PA devices (without any output capacitance). Practical devices, however, do have significant output capacitance along with package parasitics. It was shown in [3], [4] that these device output capacitances can be compensated in a wideband manner by absorbing them in the impedance inverter. Please note that in our design, to absorb all parasitics in the "artificial" transmission line, the addition of some external capacitors is still needed as shown in Fig. 3. An Ampleon high voltage LDMOS device (BLF888D) was selected to demonstrate this concept. These devices can provide high bandwidth in combination with high power and excellent ruggedness. The schematic of the wideband impedance inverter along with the wideband output capacitance compensation network is shown in Fig. 3. Moreover, the DPA is matched from the combining point impedance (1.25Ω in this case) to 50Ω by using a wideband multi-segment impedance transformer [7]. The circuit was fabricated using standard Rogers 3000 series PCB material and is shown in Fig. 4.

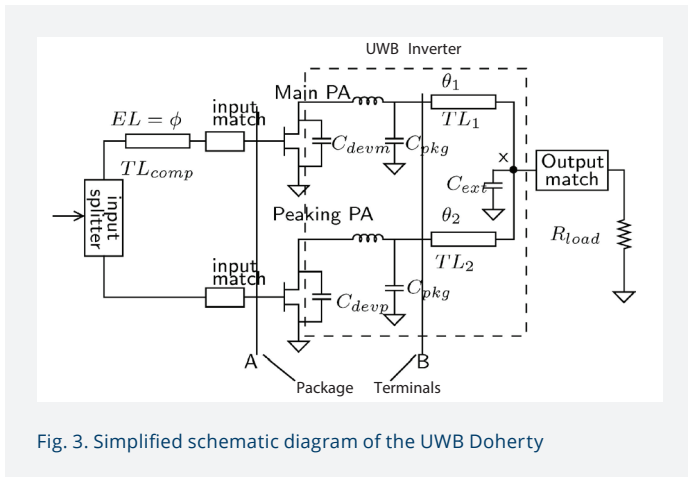

Fig. 3. Simplified schematic diagram of the UWB Doherty

B. Input Circuit Design

To achieve the maximum peak power capability of the wideband DPA, the output power of both devices is combined in phase at the power combining node (node 'x' in Fig. 3). It can also be deduced from Fig. 1a that these phase relations can be achieved by adding a $\lambda/4$ transmission line in front of the main device in combination with an in-phase power splitter as shown in Fig. 3. Please note that for the $\lambda/4$ transmission line to work properly as a phase compensator, it is important that

the inputs of the PA devices are reasonably matched. Otherwise, the reflections from the PA devices will disrupt the actual phase relations at the gates (and thus at the outputs) of the PA devices. Broadcast amplifiers, however, when aiming for a flat gain vs. frequency response, are typically designed with high reflection losses (~ -2 dB) at lower frequencies to compensate for the 6 dB / octave gain slope inherent to LDMOS PA devices. For this reason it is essential to use an input splitter which keeps the PA devices isolated from each other over the desired bandwidth in order to minimize the impact of input reflections. The use of a double-stage Wilkinson power divider [8] in combination with a QWTL in front the main device keeps the phase error below 5 degrees over the desired bandwidth and achieves the required isolation.

5. Picture and Measurements

The prototype amplifier was built by using the BLF888D. PC board material is Rogers 3003 and 3010. The circuit is shown in Fig. 4. The wideband DPA was measured using pulsed RF and DVB-T signals. The pulsed conditions were a pulse width of 100 μ s and duty cycle of 10 %. The measured pulsed RF efficiency (Fig. 5) of the DPA shows the capability of DPA to maintain high efficiency at back-off power levels over the quite wide range of frequencies. Moreover, in order to measure the performance of DPA with modulated signals, a commercially available DVB-T exciter was used. The measured efficiencies are shown in Fig. 5, which demonstrate that DPA is able to maintain average efficiencies ranging from 38 % to 47 % over the desired UHF band. Please note that the input PAR of the DVB-T signal is 9.5 dB and the PA was allowed to compress at most by 1.5 dB. As such the resulting PAR at the output of the PA was always more than 8.0 dB over the desired band. All efficiency, gain and power measurements were performed under these constraints. Pre-distortion was also performed, using the same DVB-T exciter. As shown in Fig. 7, the proposed wideband DPA meets the linearity requirement for broadcast (-38 dBc) over the entire 470 - 803 MHz band.

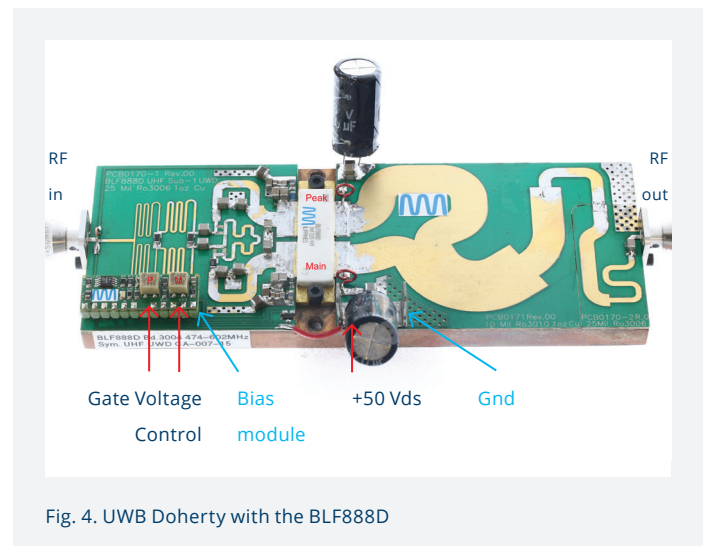

Fig. 4. UWB Doherty with the BLF888D

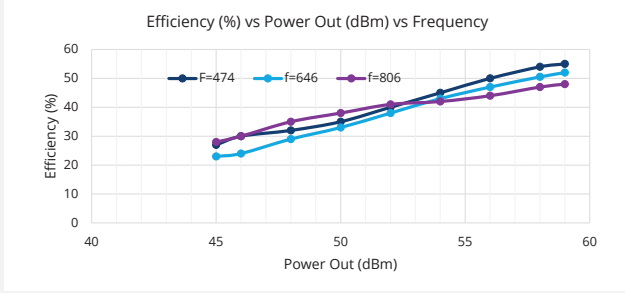

Fig. 5. Pulsed RF Efficiency of the BLF888D UWB Doherty vs Power Out

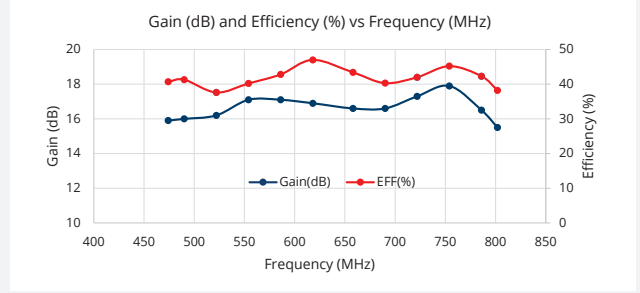

Fig. 6. Measured Gain (dB) and Efficiency of the BLF888D UWB Doherty at Pout = 115W avg.

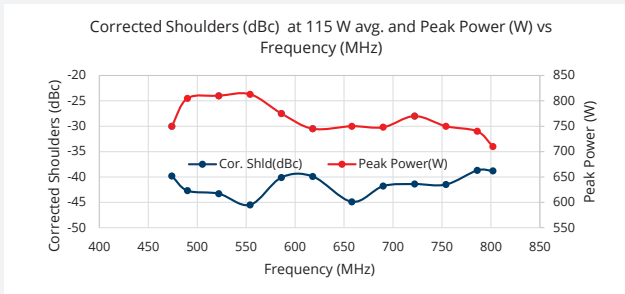

Fig. 7. Corrected shoulders (115 W avg.) with a commercial DVB-T exciter and Peak Power (W)

Main Amplifier	Peak Amplifier	Freq (MHz)	DVB-T P _{OUT} (W)	Configuration	V _{DS} (V)	Modulation	Gain (dB)	Drain Eff (%)	ACPR+/- 4.3 MHz (dBc)	Report
BLF888B	BLF888B	743 - 803	200	VERY NARROW SYM	50	ISDB-T	18.2 - 18.5	39.1 - 42.5	< -44	CA-115-12
BLF888A	BLF888A	680 - 725	200	NARROW SYM	50	DVB-T	17.0 - 18.7	40.0 - 45.0	< -20	NA-1034
BLF888A	BLF888A	470 - 870*	200	NARROW SYM	50	DVB-T	> 15	> 43	< -26	AN11325
BLF888D	BLF888D	473 - 803	> 110	SYM UWB	50	DVB-T	> 16.3	> 39.5	< -38	CA-132-13
BLF888D	BLF888D	473 - 870	115	SYM UWB	50	ISDB-T	> 15.4	> 41	< -39	CA-398-13
BLF888D	BLF888D	474 - 603	130	SYM Wideband	50	DVB-T	> 20	> 46	< -40.5	CA-036-15
BLF888D	BLF888D	474 - 806	115	SYM Wideband	50	DVB-T	> 16	> 40	< -38	NA-1820
BLF888E	BLF888E	470 - 608	150	ASYM Wideband	50	DVB-T	> 16	> 46	< -38	CA-186-15
BLF888E	BLF888E	600 - 700	150	ASYM Wideband	50	DVB-T	> 16	> 50	< -38	AR162211
BLF888E	BLF888E	650 - 790	150	ASYM Wideband	50	DVB-T	> 15	> 49	< -38	NA2503
BLF888B	BLF8xx	470 - 803	-	ASYM UWB	50	DVB-T	tbd	tbd	tbd	tbd

*=With Bandsplits determined by Doherty combiner
Each Main or Peaking Amplifier is one side of "push-pull" device

Fig. 8. Ampleon Doherty Reference Designs / Demo Boards

6. Doherty Roadmap and Reference Design/Demo Board List

Ampleon has since developed a family of wideband Doherty amplifiers in the 470 - 860 MHz range. These amplifiers are based on Ampleon's 50 V LDMOS devices which are optimized for Doherty circuit operation. These wideband Doherty amplifiers can provide 50 - 150 W DVB-T average power with drain efficiencies of 40 - 50 %. Ampleon has a family of demo boards (reference design) that are plug-and-play and available for potential customers. The lower power versions (< 100 W) are omitted from the list. Details on Ampleon's demo board list are shown above.

As shown above most of the demo board circuits are symmetric Doherty configurations, except for the last four demo boards listed, which are asymmetric Doherty's. There are numerous articles in the literature on the Asymmetric Doherty concept and its improvement over the symmetric Doherty topology.

The last column in the table above shows the report number. These reports consist of measured data, PC layout, schematics and BOMs for the associated demo board. For more information or to receive a copy of these reports, please contact Ampleon sales at sales@ampleon.com

Ampleon has a detailed roadmap for continued performance improvement of the UWB Doherty circuit topology. Some of the key items on our roadmap are:

- Gen9 High Voltage LDMOS family-introduction in 2nd half 2016
- BLF898 = BLF888A + 50 % POUT (samples available)
- Asymmetrical Odd Mode Ultra-Wideband Doherty with BLF888B / BLF898
- Air-cavity plastic package introduction in UHF portfolio in 2nd half 2016

These items will allow Ampleon to achieve performance improvements in power, bandwidth and efficiency from the best shown with the 150 W average BLF888E in the report AR162211 from May 2016. Ampleon will provide updates and information on progress in these areas to key customers.

7. Operating Cost Impact

Power usage is a big concern for the TV transmitter operator. The impact of the UWB Doherty and its efficiency improvement compared to conventional Class AB operation is significant. Fig. 9 below shows the impact of efficiency on operating cost.

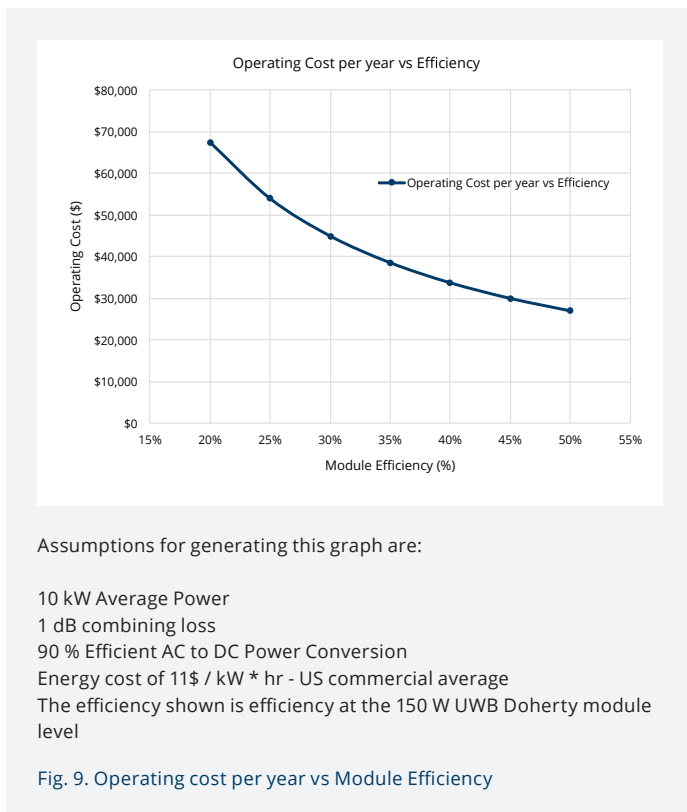

8. Conclusions / Summary

In this paper we have presented a design approach for the realization of high-power wideband Doherty amplifiers, which can cover up to 50 % - 60 % fractional bandwidth. This large frequency range is enabled by the use of a wideband impedance inverter along with a wideband capacitance compensation and matching strategy. The key achievement and importance to industry lies in the fact that these results were achieved by using standard 50 V LDMOS devices along with an easy to implement passive input splitter. This approach allows low-cost energy-efficient high power wideband amplifier implementations and easy system integration. The realized wideband DPA demonstrator covers the entire UHF TV band (470 - 803 MHz) with an average efficiency of 38 % to 47 % (at $P_{avg} = 115$ W) while maintaining peak power capability > 750 W over the entire band. As such, this demonstrator offers 15 - 20 % more efficiency [9], [10] than the currently used wideband class-AB power amplifiers in today's broadcast transmitter systems. This is the best achieved bandwidth of a DPA to date.

We have also presented Ampleon's Doherty demo board list along with a Doherty device roadmap. The key items on our roadmap will allow even more improvement over the 47 % efficient 150 W DVB-T Doherty Amplifier than we have achieved so far.

An operating cost estimate shows the potential for a \$ 25 K reduction in annual operating costs for a 10 kW transmitter.

Interested parties should contact sales@ampleon.com for further information on progress and performance improvements. Ampleon is interested in talking to any potential customers who have not investigated the Doherty concept for improving the efficiency of their TV transmitter.

References

- [1] J.H. Qureshi, W. Sneijders, R. Keenan, L.C.N. de Vreede and F. van Rijs "A 700-W Peak Ultra-Wideband Broadcast Doherty Amplifier" IEEE MTT-S, 2014.
- [2] Steve C. Cripps, "RF Power Amplifier For Wireless Communication", Artech House, 2006.
- [3] J.H. Qureshi, "High Efficiency RF Power Amplifier Architectures", TUDelft, 2012.
- [4] J.H. Qureshi, N. Li, w.c.E. Neo, F. van Rijs, I. Blednov, L.C.N.deVreede, "A Wide-Band 20W LDMOS Doherty Power Amplifier", IEEE MTT-S Int. Microwave Symp. Dig., pp. 1504-1507, May 2010.
- [5] D. Gustafsson, C. M. Andersson, C. Fager, "A novel wideband and reconfigurable high average efficiency power amplifier", IEEE MTT-S Int. Microwave Symp. Dig., June 2012.
- [6] C. M. Andersson, D. Gustafsson, J.C. Cahuana, R. HeUberg, C. Fager, "A 1-3GHz Digitally Controlled Dual-RF Input Power Amplifier Design Based on a Doherty-Outphasing Continuum Analysis", IEEE Trans. Microwave Theory & Tech., vol. 61, no. 10, pp. 3743-3752, Oct 2013.
- [7] R.W. Klopfenstein, "A Transmission Line Taper of Improved Design", Proceedings IRE, vol. 44, no. 1, pp. 31-35, Jan 1956.
- [8] B. S. Cohn, "A Class of Broadband Three-Power TEM-Mode Hybrids", IEEE Trans. Microwave Theory & Tech., vol. 16, no. 2, pp. 110-116, Feb 1968.
- [9] "BLF888AIBLF888B High Power UHF transistor (NXP Semiconductor)". www.nxp.com.
- [10] "MRFE6VP8600H High Power UHF Transistor (Freescale)", www.freescale.com.
- [11] "ETSI EN 300 744 V1.6.1 (2009-01). Digital Video Broadcasting (DVB)", ETSI, 01/2009. [Online] Available at: <http://www.dvb-h.org/technology.htm>.